

Body Storage

The Afos Compact Body Store provides a flexible, space-saving system which is cost and energy efficient.

The design prevents cross contamination, eliminates odours, reduces the risk of decomposition, ensures forensic security, promotes simple and hygienic body handling and satisfies all peak body storage demands, pressures and emergencies.



Body Storage

AFOS

Website: www.afosgroup.com / Email: info@afosgroup.com

Construction

- Modular design
- 'Tongue and groove' joint incorporating cam-locks
- Minimal site installation time
- Designed to comply with HBN 20: facilities for mortuary and post mortem room services-2005

Insulation

- External walls, roof and ceiling panels manufactured using 100mm thick rigid polyurethane
- Internal partition walls manufactured using 80mm thick rigid polyurethane foam

Panels

- Finished in white, heat laminated hard PVC coating
- Type approved by Lloyds Register No.93/00035 (EI)
- Manufactured to quality assurance standard BS EN ISO 9002
- Internal panel facings can be supplied in stainless steel finish with a thickness of 0.7mm as an optional extra

Floors

- 1.0mm 304 grade stainless steel floor pan
- Integral sealed and trapped drain, to external connection
- Wall panels are designed to close over upturned rim of the pan and are sealed during installation to provide complete waterproof joint

Drainage

- Integral drain in each chamber, mounted behind easily removable front plinth
- Drainage outlet at face of floor plinth is standard 1½" BSP push fit connection

Door Locks

- External security lock
- Interior luminescent panic release
- Door key suite numbers are available for different types of compartments

Doors

- Robust construction
- Fully insulated with 80mm thick, rigid poly urethane foam
- Finished in white, heat laminated hard PVC coating
- 170° opening of door (site conditions permitting)
- Gaskets located on inner face of door
- Gaskets easily removed for cleaning
- Seal ensures airtight integrity of each chamber

Anti Condensation Heaters

Wire armoured heater tapes are located in a recess within the front face of the door frame and are fitted as standard to freezer compartments and are optional for other compartments. Anti Condensation Heaters should be fitted for conditions where the 'Dew' point is greater than 12°C (Typically greater than 21°C 60% RH)



Door Opening Sizes

3 Tier Standard Door:	595mm x 1548mm
4/5 Tier Standard Door:	595mm x 2004mm
3 Tier Obese Door:	695mm x 1548mm
4/5 Tier Obese Door:	695mm x 2004mm
3 Tier Bariatric Door:	795mm x 1548mm
4/5 Tier Bariatric Door:	795mm x 2004mm

Other sizes available on request.

Body Storage

Body Trays

- Manufactured from 304 or 316 grade pressed stainless steel
- Robust construction
- Handles at each end

NOTE: AFOS OFFER A PASS THROUGH DOOR ARRANGEMENT ON ALL BODY STORES AS AN OPTIONAL EXTRA

Body Tray Supports

The 'drop-in' tray support rollers, which are the full width of each bay, locate in a vertical slot and can be easily removed or replaced by hand.

Manufactured from solid stainless steel shaft complete with free running polyethylene rollers to give a smooth operation and is designed to prevent any possibility of collapse onto lower trays.

NOTE: Tools are not required to make height adjustments of body tray locations

Lighting

- Door frame mounted bulkhead light fittings
- Electrical supply connected to main junction box

Pressure Relief Valve

- A pressure relief valve is fitted into a body store compartment of the 'deep freeze' type only

Alarm

- Alarm provided to indicate both low and high temperature conditions within the temperature range

Refrigerant

Refrigerants used will normally be R134a or R404a to meet current International CFC Legislation.

Refrigeration

- Evaporators stop on door opening for maximum energy saving
- Offered with customised refrigeration system
- Operating temperatures are offered at 0°C to +5°C for normal applications
- Low temp operation available at -20°C for long term body storage
- Variable temperature available as an option, at an extra cost
- Fully automatic defrost cycle

There are two typical applications that can be supplied internal ceiling mounted evaporator with remote condensing unit or fully integrated ceiling mounted unit.

Ambient Operating Temperatures

The refrigeration equipment can be supplied to suit either of the following operating conditions:

- A temperate climate at an ambient temp of 27°C
- A tropical climate at an ambient temp of 43°C

Electrical Supplies

This will normally be 415V, 3 Phase, 50Hz, 20Amps for UK usage. European or special requirements can be catered for.

Electrical Controls

An electronic control panel with temperature indication is normally supplied as standard equipment complete with volt free contacts for connection to BMS.

Further Information

If you require any further information on the AFOS product range, contact our Sales Department

Tel: + 44 (0)1482 372100
Email: info@afosgroup.com



Walk In Body Storage

AFOS

Website: www.afosgroup.com / Email: info@afosgroup.com

Construction

- Modular design
- 'Tongue and groove' joint incorporating cam-locks
- Minimal site installation time
- Designed to comply with HBN 20: facilities for mortuary and post mortem room services-2005

Insulation

- External walls, manufactured using 100mm PIR (Polyisocyanurate) to walls. U value (W/sq M K): 0.2 (R32)
- Ceiling to smaller room: 100mm PIR (Polyisocyanurate)
- U value (W/sq M K): 0.2 (R34)
- Ceiling to larger room 150 mm PIR (Polyisocyanurate)
- U value (W/sq M K): 0.15 (R48)

Panels

- Finished in white, heat laminated hard PVC coating
- Type approved by Lloyds Register No.93/00035 (EI)
- Manufactured to quality assurance standard BS EN ISO 9002
- Internal panel facings can be supplied in stainless steel finish with a thickness of 0.7mm as an optional extra

Floors

- No floor finish
- The wall panels sit in a channel fixed to the existing floor

Ceilings

- All ceilings are self supporting

Internal Fittings

- Double bumper rail on the inside of the smaller chiller

Door Locks

- External security lock
- Interior luminescent panic release

Doors

- Robust construction
- Fully insulated with 80mm thick, rigid poly urethane foam
- Finished in white, heat laminated hard PVC coating
- Gaskets located on inner face of door
- Gaskets easily removed for cleaning
- Seal ensures airtight integrity of each chamber

Large Cold Room

- One **auto** sliding door, sliding on medium duty Fermod 2400 series track with 2494SVH-EN
- Clear opening to be 120mm wide x 190mm high
- Electro/mechanical lock allowed for with safety override

Small Cold Room

- One double door having clear opening of 1830mm x 1900mm high



Chiller Cold Room Specification:

External Dimensions

Large Chiller:

Width:	9.1m
Depth:	7.4m
Height:	2.3m

Small Chiller:

Width:	4.2m
Depth:	2.8m
Height:	2.3m

Walk In Body Storage

Refrigerant

- Refrigerants used will be R134A to meet current International CFC Legislation

Small Cold Room

- Refrigerant Duty: 11,950 BTU/hr
- Condenser Water Flow: 1.4GPM
- Temperature Required: 2°C (36°F)
- Condensing Unit: HWN030X6
- Evaporator: LET140BK

Large Cold Room

- Refrigerant Duty: 21,500 BTU/hr
- Condenser Water Flow: 4.0 GPM
- Temperature Required: 2°C (36°F)
- Condensing Unit: HWN050X6
- Evaporator: LET240BK

Inclusions

- Mechanical door switches CSA Approved
- Fluorescent lights CSA Approved

Alarm

- Alarm provided to indicate both low and high temperature conditions within the temperature range

Ambient Operating Temperatures

- A temperate climate at a maximum ambient temp of 27°C

Electrical Controls

An electronic control panel with temperature indication is normally supplied as standard equipment complete with volt free contacts for connection to BMS.

Electrical Supplies

Refrigeration equipment will require a 208 Volt, 3 Phase, 60Hz electrical supply

Further Information

If you require any further information on the AFOS product range, contact our Sales Department:

Tel: + 44 (0)1482 372100
Email: info@afosgroup.com

Mortuary Cold Room Racking

AFOS

Website: www.afosgroup.com / Email: info@afosgroup.com

Why AFOS

AFOS have a global reputation for the design and manufacture of high quality, stainless steel Mortuary equipment which has been installed in pharmaceutical and medical facilities throughout the world over the last 25 years. Our design team can also provide bespoke systems to meet the needs of individual clients.

Overview

- Stainless steel construction grade 304
- Sections are braced together with stainless steel cross-members and appropriately bolted
- Trays are in grade 304 stainless steel
- The trays have a handle at both ends
- Rollers are manufactured from 20mm stainless steel bar
- All rollers have two polypropylene guide rollers
- The rack is flexible and adjustable from 3 to 5 tiers
- The racking roller system will interface seamlessly with the AFOS stacking trolley
- Each tray can hold a maximum of 50st/315.5 kilos
- Each 4 tier bay can hold a maximum of 135st/ 857.28 kilos
- The full product is maintenance free as general cleaning agents can be used



To Suit Tray Sizes:

Width: 567mm
Width: 667mm
Width: 730mm

Further Information

If you require any further information on the AFOS product range contact:

Tel: + 44 (0)1482 372100
E-mail: info@afosgroup.com

AFOS reserve the right to alter the specifications above without notice

Perinatal Body Store

AFOS

Website: www.afosgroup.com / Email: info@afosgroup.com

Standard Features

- Fully Automatic Operation
- Fan Assisted Cooling
- Electronically Controlled
- Fitted Castors
- Lock Fitted
- Digital Temperature Display
- Replaceable Door Gasket
- Auto Defrost
- Self Closing Door
- Adjustable Shelving
- Reversible Door

Single Store

Temp Range: -2°C/+8°C
Refrigerant: R134A
Type of Defrost: Automatic
No. Shelves: 5
Exterior Finish: Stainless steel
Interior Finish: Stainless steel
Power required: 120V

Dimensions

Weight: 131kg / 289lb
Capacity: 100L (24.7 Cubic feet)
External Height: 2040mm / 80"
External Width: 750mm / 30"
External Depth: 800mm / 31"
Internal Height: 1430mm / 56"
Internal Width: 600mm / 23"
Internal Depth: 655mm / 26"

Available Options

- Freezer option
- Double store also available



AFOS reserve the right to alter the specifications above without notice

Perinatal Body Store

AFOS

Website: www.afosgroup.com / Email: info@afosgroup.com

Standard Features

- Fan Assisted Cooling
- Electronically Controlled
- Fitted Castors
- Lock Fitted
- Digital Temperature Display
- Replaceable Door Gasket
- Auto Defrost
- Self Closing Door
- Adjustable Shelving

Single Store

Temp Range: -2°C/+8°C
Refrigerant: R134A
Type of Defrost: Automatic
No. Shelves: 10
Exterior Finish: Stainless steel
Interior Finish: Stainless steel
Power required: 120V

Dimensions

Weight: 226 kg / 498lb
Capacity: 1400 L (49.4 Cubic feet)
External Height: 2040 mm / 80"
External Width: 1500 mm / 59"
External Depth: 800 mm / 31"
Internal Height: 1430 mm / 56"
Internal Width: 1350 mm / 53"
Internal Depth: 655 mm / 26"

Available Options

- Freezer option
- Single store also available



AFOS reserve the right to alter the specifications above without notice

Bariatric Body Stretcher

AFOS

Website: www.afosgroup.com / E-mail: info@afosgroup.com

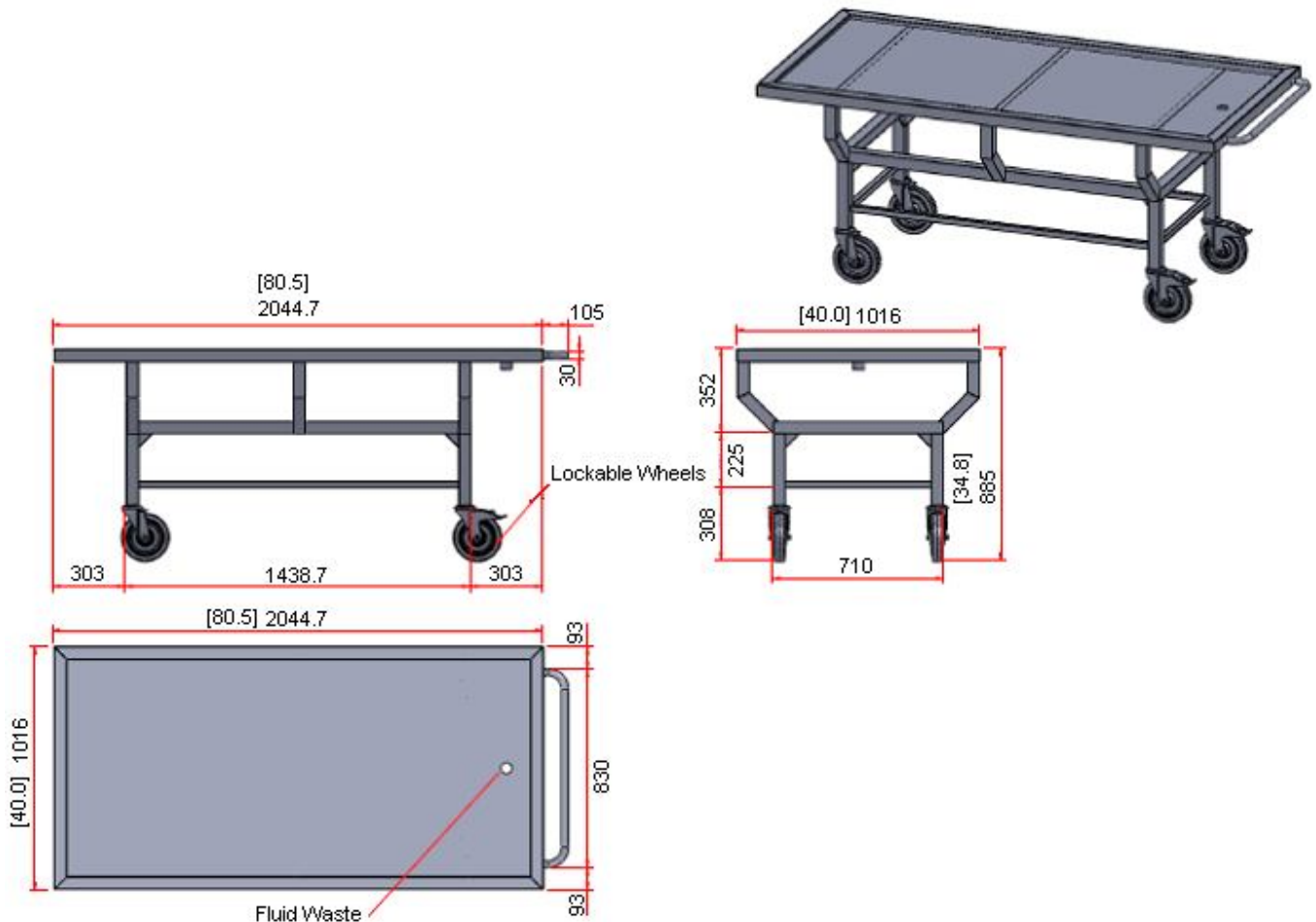

Why AFOS?

AFOS have a global reputation for the design and manufacture of high quality, stainless steel Mortuary equipment which has been installed in pharmaceutical and medical facilities throughout the world over the last 50 years. Our design team can also provide bespoke systems to meet the needs of individual clients.

Overview

- Suitable for Bariatric Cadavers
- High quality stainless steel throughout
- 1000Kg weight limit
- Lockable wheels
- 8" non-marking, low resistance wheels
- 1½" BSP waste socket

Technical Specification

Dimensions:

Width:	40.0"
Length:	80.5"
Capacity:	1000Kg

Further information

If you require any further information on the product range available from AFOS, contact our Sales Department:

Tel: +44 (0) 1482 372100
Email: info@afosgroup.com

AFOS reserve the right to alter the specifications above without notice

Ritual Washing Table

AFOS

Website: www.afosgroup.com / Email: info@afosgroup.com

Why AFOS

AFOS have a global reputation for the design and manufacture of high quality stainless steel medical equipment.

AFOS specialise in providing a total design, manufacture and installation service of mortuary and pathology equipment including autopsy tables and body storage.

AFOS have successfully provided solutions for global healthcare and are active in realising PFI opportunities throughout the UK.

AFOS not only meet existing health and safety standards, we exceed them thus maintaining maximum protection for the clinician.

The innovative AFOS down draught technology helps eliminate odours and controls harmful pathogens, ensuring the highest possible level of clinical effectiveness is achieved.

Overview

- High quality stainless steel throughout
- Recessed top to allow feet space when standing at table
- Top is one integral section, fully welded and polished
- One quick release trigger operator shower and hose (thermostatically controlled)
- Hose can be at either end of table
- Adjustable feet

Services

Services to the AFOS Body Washing Table are as scheduled.

All services are finished with 15mm copper pipe tails and waste 1½" BSP.

Material Specification

Work top:	316 stainless steel (14swg)
Cover Panel:	304 stainless steel (18swg)
Support Frame:	304 stainless steel 50 x 50 square tube 1.5mm thick wall
Waste pipe:	316 stainless steel 1½" BSP
Water Flow:	20L/min at 2 Bar
Remote Control:	Valve head chrome finish



Technical Specification

Dimensions

Length:	2100 mm
Depth:	800 mm
Height:	900 mm

Further Information

If you require any further information on the product range available from AFOS, contact our Sales Department:

Tel: + 44 (0)1482 372100
E-mail: info@afosgroup.com

AFOS reserve the right to alter the specifications above without notice

Mortuary Lifting Trolley

AFOS

Website: www.afosgroup.com / E-mail: info@afosgroup.com

Why AFOS?

AFOS have a global reputation for the design and manufacture of high quality stainless steel mortuary equipment which has been installed in pharmaceutical and medical facilities throughout the world over the last 50 years. Our design team can also provide bespoke systems to meet the needs of individual clients.

Overview

- Low maintenance
- Load cell weighing facility complete with tray tare
- Digital readout in stones or kilos
- Accuracy to 0.5kg
- Lifts to all rack heights
- Rapid roll transfer system
- Hydraulic lifting mechanism
- Approx 300 lifts between charges
- Accessibility is head to toe and toe to head
- 2 Lockable wheels, 160mm diameter
- 4 Swivelling wheels
- Accommodates all tray sizes
- Optional tray retraction system

Material Specification

- Powder coated in white
- Length: 2400mm
- Width: 730mm
- Closed Height: 400mm
- Fully extended: 1850mm

Load Capacity: 50 Stones / 318kg

Further information

If you require any further information on the product range available from AFOS, contact our Sales Department:

Tel: +44 (0) 1482 372100

Email: info@afosgroup.com



AFOS reserve the right to alter the specifications above without notice

Mortuary Lifting Trolley

AFOS

Website: www.afosgroup.com / Email: info@afosgroup.com

Why AFOS

AFOS have a global reputation for the design and manufacture of high quality, stainless steel Mortuary equipment which has been installed in pharmaceutical and medical facilities throughout the world over the last 50 years. Our design team can also provide bespoke systems to meet the needs of individual clients.

Overview

12V Electro Unit Hydraulic Short Top
Constructed in 1½" / 38mm square tube, 12, 14 and 16 gauge
Available in both 3 and 4/5 tier options

Material Specification

3 Tier Heavy Duty

Length:	2020mm / 79 ½"
Width:	30mm / 29"
Closed Height:	400mm / 16"
Fully extended:	1727mm / 68"
Lift:	1327mm / 54"
Load Capacity:	285kg

4/5 Tier

Length:	2082mm / 82"
Width:	730mm / 28"
Closed Height:	400mm / 16"
Fully extended:	1930mm / 76"
Lift:	1530mm / 61"
Load Capacity:	158kg

Optional Extras

Electronic weight device

Further information

If you require any further information on the product range available from AFOS, contact our Sales Department:

Tel: +44 (0) 1482 372100

Email: info@afosgroup.com

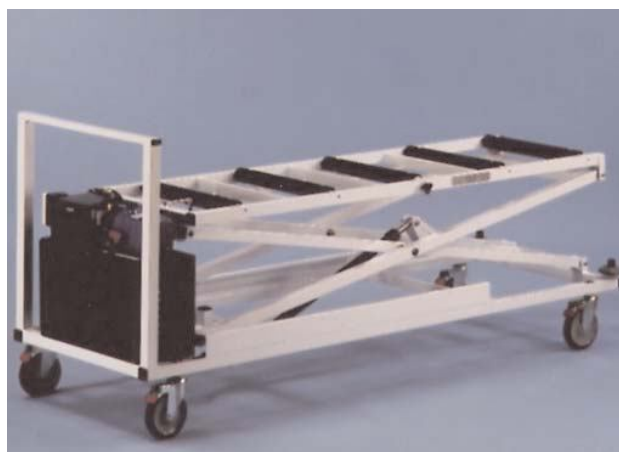

AFOS reserve the right to alter the specifications above without notice

Body Lifter

AFOS

Website: www.afosgroup.com / Email: info@afosgroup.com

Why AFOS

AFOS have a global reputation for the design and manufacture of high quality stainless steel medical equipment.

AFOS specialises in providing a total design, manufacture and installation service of mortuary and pathology equipment including autopsy tables and body storage.

AFOS have successfully provided solutions for global healthcare and are active in realising PFI opportunities throughout the UK.

AFOS not only meet existing health and safety standards, we exceed them thus maintaining maximum protection for the clinician.

The innovative AFOS down draught technology helps eliminate odours and controls harmful pathogens, ensuring the highest possible level of clinical effectiveness is achieved.

Overview

Electro-hydraulic lift and transport trolley

Maximal load capacity: 250 kg
Size: 2430 x 870 x 300/1850mm

Stable construction of stainless steel (1.4301).
Electro-hydraulic height adjustment, electric control, with charger.
Smooth height adjustment by using foot push buttons.
Trolley with master switch and signal of battery charging progress.
Upper frame with roller system for loading trays and coffins, additional the holding device system to secure the tray.
Two buffers at the front of trolley and fixed handle on each side.

The trolley with four road wheels, diameter 125mm, tread: elastic-tyre, non-marking. Two fitted and two swivel wheels, all lockable.
The handle is height adjustable, easy disassembly.

Further information

If you require any further information on the product range available from AFOS, contact our Sales Department:

Tel: +44 (0) 1482 372100
Email: info@afosgroup.com



Floor Scales

AFOS

Website: www.afosgroup.com / E-mail: info@afosgroup.com

Why AFOS?

AFOS have a global reputation for the design and manufacture of high quality, stainless steel Mortuary equipment which has been installed in pharmaceutical and medical facilities throughout the world over the last 50 years. Our design team can also provide bespoke systems to meet the needs of individual clients.

Overview

- Push tare button
- 1000Kg capacity
- Platform level with the floor for easy access
- Multi purpose weighing.
- Weight displayed on either wall mounted or recessed digital readout
- 1" high LCD readout
- Digital indicator is AC powered for continual use
- Choice of pound or kilogram readings
- Optional handrail
- Pit frame
- Length: 82.5"
- Width: 49.2"

Further information

If you require any further information on the product range available from AFOS, contact our Sales Department:

Tel: +44 (0) 1482 372100

Email: info@afosgroup.com



AFOS reserve the right to alter the specifications above without notice

Concealment Trolley

AFOS

Website: www.afosgroup.com / Email: info@afosgroup.com

Variable Height

- Electrically operated
- Heavy duty reinforced PVC cover
- Cover locates over side rails
- Height adjustable - 560mm to 1275mm / 22" to 50"
- Smooth and straight vertical lift
- Uninterrupted access to the top when cover removed and sides lowered
- Bumper bar/push handle at both ends of trolley.
- 200mm base plate castors (2 braking and 2 directional locking)
- Maximum Safe working load 190Kg / 418lbs
- Linak electric actuator, operated by rechargeable battery

Battery chargeable by simple wall socket charger plugging into handset. There is an audible warning when 50% of charge remains.

Dimensions

Height: 670mm / 26"
Width: 2270mm / 89"
Depth: 740mm / 29"
Weight: 101kg / 222lb

Tray Options

Fixed Tray
Removable Tray
Version compatible with AFOS standard and obese trays available on request

Fixed Height

- Fixed height trolley
- Drop sides
- Flexible cover
- Side rails lower to provide level access from either side of the trolley
- 585mm / 23" between sides
- support drop over PVC cover
- Protective bumper bar fitted at each end
- 200mm 8" base plate castors (2 braking and 2 directional locking)

Dimensions

Height: 670mm / 26"
Width: 2080mm / 82"
Depth: 855mm / 34"
Weight: 55kg / 121lb



AFOS reserve the right to alter the specifications above without notice

Viewing Bier Trolley

AFOS

Website: www.afosgroup.com / Email: info@afosgroup.com

AFOS have a global reputation for the design and manufacture of high quality stainless steel medical equipment.

AFOS specialises in providing a total design, manufacture and installation service of mortuary and pathology equipment including autopsy tables and body storage.

AFOS have successfully provided solutions for global healthcare and are active in realising PFI opportunities throughout the UK.

AFOS not only meet existing health and safety standards, we exceed them thus maintaining maximum protection for the clinician.

The innovative AFOS down draught technology helps eliminate odours and controls harmful pathogens, ensuring the highest possible level of clinical effectiveness is achieved.

Overview

Maximum load to 30 stones
Length 2079mm x Width 762mm

304 grade stainless steel construction
Compatible with body trays
Roller assembly interfaces with body stacking trolley
Swivelling locking castors

Table completely made of 304 grade stainless steel
Table base with four wheels, diameter 125 mm, tread: elastic-tyre, non-marking.

The body tray, transfers directly from the body stacking trolley to the viewing trolley, reducing manual handling.

There is no religious marking on the drapes, they are available in a choice of colours. The velvet drapes are detachable from the trolley frame.



AFOS reserve the right to alter the specifications above without notice